

# AP1000F WHEEL PAVER

## PRODUCT SPECIFICATIONS

CAT

Engine - powertrain	
CAT C7.1 ACERT Engine	168 kW / 225 hp
Engine Speed - maximum / minimum	2,200 / 1,100 rpm
Eco-mode	1,650 rpm
Screed Heating - Standard width (quiet)	1,300 rpm
Screed Heating - W/extensions (quick)	1,300 to 2,200 rpm
Speed Ranges	
Paving	76 mpm / 250 fpm
With Tamper-bar Screed	25 mpm / 82 fpm
Travel	19.9 km/hr
Weights	
APF1000F Paver Only - Shipping	20,602 kg
Capacities	
Maximum Throughput Capacity	1,602 tonnes/h / 1,766 tph
Hopper Capacity - With tunnels	
Standard Entry Hopper	7.6 m <sup>3</sup> / 267 ft <sup>3</sup>
Low Entry Hopper	8.1 m <sup>3</sup> / 286 ft <sup>3</sup>
Fuel Tank	348 L
DEF (Urea) Capacity	19.1 L
Engine Oil	16 L
Cooling System	45.4 L
Hydraulic Tank	219 L
Screed Specifications	
Paving Range	3.0 - 5.95 m
Maximum Paving Width - With extensions	7.65m
Maximum Paving Depth	305mm
Crown Range - SE60 V, V XW*	-3% to +10%
Crown Range - SE60 VT XW**	-1.5% to 5%
Extender Height Range	-20mm to +50mm
Extender Slope Range	-3% to +10%
Fuel Burn	
Low	9.5 - 15.1 Litres per hour
Medium	15.1 - 18.9 Litres per hour
High	18.9 - 24.6 Litres per hour

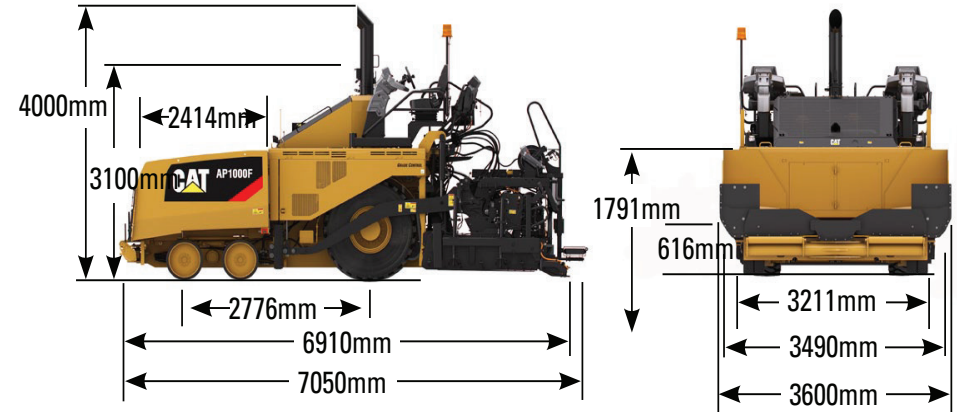

DISCLAIMER: This Product Specification Sheet was produced 01/2020. Every effort has been made to ensure that the content is accurate, however the contents are subject to change. Information contained in this Specification Sheet is for general information only and does not purport to be comprehensive, current only at the time it is placed in this document compiled from manufacturer and industry sources; and not intended to provide nor make any recommendation upon which you should rely for any purpose whatsoever. Ezyquip Hire makes no warranty express or implied, including without limitation any warranty of merchantability or fitness for any particular purpose. Ezyquip Hire shall not be liable for any special, incidental, or consequential damages or loss of profits resulting from use of or misuse of the general information provided in this document.